

**SCA 2026**  
Supercomputing Asia  
Gathering the Best of HPC in Asia

**HPC  
Asia  
2026**

# SCA/HPCAsia 2026

Everything with HPC-AI, Cloud, QC and Future Society

**Date** **January 26-29, 2026**

**Venue** **Osaka International Convention Center  
(Osaka, Japan)**

**Sponsorship Prospectus**

◇Host Organization  
SupercomputingAsia 2026  
The International Conference on High Performance Computing in Asia-Pacific Region 2026

◇Sponsorship Secretariat of SCA/HPCAsia 2026  
c/o Convention Linkage, Inc.  
11F PIAS TOWER, 3-19-3 Toyosaki, Kita-ku, Osaka-city, Osaka 531-0072, Japan  
E-mail: sponsor-sca\_hpcasia\_2026@c-linkage.co.jp Tel: +81-6-6377-2188

<https://www.sca-hpcasia2026.jp/>



as of July 30, 2025

## SCA/HPCAsia 2026

The **SupercomputingAsia (SCA)** is a major annual international HPC event in Asia established in 2018. The conference is co-organized by HPC centers from Australia, Japan, Singapore, and Thailand, and has become a key networking and collaboration platform for the regional and global supercomputing community, for both the public and private sectors.

The **International Conference on High Performance Computing in Asia-Pacific Region (HPCAsia)** is an international conference series for the Asia Pacific region on HPC technologies, that promote exchange of ideas, research results, and case studies related to all issues of high-performance computing.

### In Osaka, SCA and HPCAsia cooperate again and jointly host SCA/HPCAsia 2026.

The collaborative and collective strength from two of Asia's established conferences creates synergy among key HPC researchers, academics, technology specialists and industry leaders from across the region and beyond. Under the title "Everything with HPC - AI, Cloud, QC and the Future Society," AI, cloud and QC communities along with supercomputing community are invited to get together to create the future.

### Opportunities and Benefits for Exhibitors:

- Showcase your cutting-edge technology in the field of supercomputing, AI, big data, cloud computing, quantum computing and semiconductors.
- Reach new domestic and international customers.
- Raise company profile through networking and sponsorship opportunities.
- Build business relationships with major global companies and leading researchers.
- Attract global talent from Asia and other countries.

### SCA/HPCAsia 2026 Program (Tentative)

|         | January 26 (Mon)       | January 27 (Tue)   | January 28 (Wed)  | January 29 (Thu)   |
|---------|------------------------|--|---|--|
| AM      | Workshops<br>Tutorials | Opening Session<br>Keynote Speech<br>Industry Session<br>Research Session<br>Invited Session | Keynote Speech<br>Industry Session<br>Research Session<br>Invited Session | Keynote Speech<br>Industry Session<br>Research Session<br>Invited Session  |
| Noon    | Lunch                  | Lunch  | Lunch   | Lunch  |
| PM      | Workshops<br>Tutorials | Industry Session<br>Research Session<br>Invited Session                                      | Industry Session<br>Research Session<br>Invited Session                   | Industry Session<br>Research Session<br>Invited Session<br>Closing Session |
| Evening | Reception (TBD)        | Banquet (TBD)  |   |  |
| All Day |                        |  | Exhibition  |  |

\*Excursion to R-CCS and Kobe City (Date: TBD)

# SPONSORSHIP PACKAGES

|   | DIAMOND<br>JPY<br>100,000,000 | PLATINUM<br>JPY<br>5,000,000 | GOLD<br>JPY<br>3,000,000 | SILVER <sup>*2</sup><br>JPY<br>1,000,000 | BRONZE <sup>*2</sup><br>JPY<br>500,000 | START-UP <sup>*1</sup><br>JPY<br>200,000 |
|---|-------------------------------|------------------------------|--------------------------|--|--|--|
| <b>EXHIBITION SPACE</b>   |                               |                              |                          |  |  |  |
| Raw space for sponsor build-up<br>Optional items per one (1) space:<br>•Back panel<br>•One (1) display table and two (2) chairs<br>*Start-up Package (per one (1) space) includes:<br>•Back panel (H2.7m x W0.9m)<br>•One (1) display table | 1<br>4m x 8m                  | 1<br>4m x 4m                 | 1<br>2m x 4m             | 1<br>2m x 3m                             | 1<br>2m x 2m                           | 1<br>1m x 1m<br>*Built-in booth          |
| <b>LUNCH SPEAKER SESSIONS</b>   |                               |                              |                          |  |  |  |
| One(1) 60-minute speaking slot during lunch time.<br>Sponsors are responsible for the program including lunch arrangement.  | ✓                             | ✓                            | ✗                        | ✗  | ✗                                      | ✗  |
| <b>EXHIBITOR'S SUITE</b>  |                               |                              |                          |  |  |  |
| Sponsors can apply for the exhibitor's suite.<br>Diamond, Platinum sponsors will receive priority in the application process.   | ✓                             | ✓                            | ✓                        | ✗  | ✗                                      | ✗  |
| <b>COMPLIMENTARY PASSES</b>   |                               |                              |                          |  |  |  |
| Conference Passes<br>Includes onsite access to all conference sessions and networking events<br>(standard price: JPY 95,000).   | 20                            | 10                           | 6                        | 2  | 1                                      | 1  |
| Exhibition Passes<br>Includes access to the exhibition area only<br>(standard price: JPY 20,000).   | 20                            | 10                           | 6                        | 2  | 1                                      | 1  |
| <b>LOGO EXPOSURE</b>  |                               |                              |                          |  |  |  |
| •Company logo on the SCA/HPCAsia 2026 official website<br>•Company logo/name in general conference materials<br>(e.g. program, proceedings, handouts)   | ✓                             | ✓                            | ✓                        | ✓  | ✓                                      | ✓  |
| <b>PROMOTIONAL MATERIALS</b>  |                               |                              |                          |  |  |  |
| One (1) corporate brochure (maximum size: A4) and one (1) corporate gift inserted into the conference bag.  | ✓                             | ✓                            | ✓                        | ✓  | ✓                                      | ✓  |
| <b>ATTENDEE CONTACT LIST(opt-in)</b>  |                               |                              |                          |  |  |  |
| The contact information of the registered attendee (name, company name, job title, email address, country).   | ✓                             | ✓                            | ✓                        | ✗  | ✗                                      | ✗  |
| <b>EXHIBITORS FORUM</b>   |                               |                              |                          |  |  |  |
| 15-minute onsite speaking opportunity in the exhibition hall.   | 2                             | 1                            | 1                        | 1  | 1                                      | 1  |

\*1 Applicable to companies established after January 2016.

\*2 Japanese universities and research institutions will receive a discount when applying for the SILVER or BRONZE package. The discounted price will be informed separately. Note: Consumption tax is included in all prices.

# OTHER CUSTOMIZED SPONSORSHIP STREAMS

Customized packages can be designed to suit your specific requirements or as an addition to standard sponsorship options.

## Lanyards: JPY 500,000

Add your company name or logo to the SCA/HPCAsia 2026 conference lanyard.

## Conference Bag: JPY 400,000 – 600,000

Add your company name or logo to the SCA/HPCAsia 2026 conference bags. The cost varies depending on the number of sponsors.

## Beverage Station: JPY 600,000

Company name displayed at the beverage station.

Opportunity to supply following branded items at the beverage station.

Water bottles (500 bottles) : **JPY 500,000**

Paper cups (3,000 cups) : **JPY 400,000**

## Floor Map and Exhibit Locator Floorplan: JPY 2,500,000

Will be handed out to participants on site. The cost can be shared with multiple companies.

## Signs and Graphics : 800,000 – 2,000,000

You can design your company's advertisements.

1. Standing Sign Board (1F) (W900 × H3000) : **JPY 800,000** [Signboard Location](#)
2. Standing Sign Board (10F) (W4500 × H2400) : **JPY 600,000** [Signboard Location](#)
3. Elevator Door Wrap : **JPY 2,000,000 (6 units/floor) or JPY 1,000,000 (3 units/floor)** [Signboard Location](#)

\*Kindly refer to the respective links for each location.

Kindly refer to the respective links for each application form.

Note: Consumption tax is included in all prices.

Please contact [sponsor-sca\\_hpcasia\\_2026@c-linkage.co.jp](mailto:sponsor-sca_hpcasia_2026@c-linkage.co.jp) for inquiries.

# OTHER CUSTOMIZED SPONSORSHIP STREAMS

## Reception Dinner Sponsor on January 26: JPY 4,000,000 – 5,000,000

Opportunity to deliver opening remarks and display your company name at the reception venue. The cost may vary depending on the venue, the number of dishes to be served and the content. The cost can be shared between multiple companies.

## Banquet Dinner Sponsor on January 27: JPY 10,000,000

Opportunity to deliver opening remarks and display your company name at the banquet venue. The cost may vary depending on the number of dishes served and their content. The cost can be shared among multiple companies.

## Lunch Sponsor (Exhibition hall) : 1,000,000 – 3,500,000

Company name displayed in the lunch area and announcement by the conference organizer.

1. January 26: **JPY 1,000,000**. Bento box served to the Workshop/Tutorial participants.
2. January 27, 28, 29: **JPY 3,500,000** per day/sponsor. Buffet provided in the exhibition area.

## Morning/Afternoon Tea Break Sponsorship (Exhibition Hall) : JPY 2,000,000 / day

Company name displayed and/or opportunity to supply branded items (e.g., cups, napkins)

Paper cups (1,000 cups): **JPY 200,000**

Napkins (1,000 napkins): **JPY 100,000**

## Japanese Tea Ceremony Stand Sponsorship: JPY 800,000 / 2 hours

Opportunity to offer Japanese tea ceremony experience with matcha and seasonal sweets. Company name displayed at the Japanese tea ceremony space and announcement by the conference organizer.

## Food Stand Sponsorship (Banquet) : JPY 500,000 – 700,000

Company name displayed at the food stand during the banquet.

Food stand include sushi, udon, takoyaki, tempura, oden, etc. Costs varies depending on the type of food stand and the number of items served.

## Excursion Sponsorship (Kobe and Fugaku Tour) : JPY 400,000

Opportunity to provide a bus tour of the RIKEN Center for Computational Science and Kobe City. Other promotional materials and activities can be arranged upon request for an extra fees.

Note: Consumption tax is included in all prices.

Please contact [sponsor-sca\\_hpcasia\\_2026@c-linkage.co.jp](mailto:sponsor-sca_hpcasia_2026@c-linkage.co.jp) for inquiries.

# SPONSORSHIP REGISTRATION PROCESS

## Schedule

|   |                                   |
|---|-----------------------------------|
| Sponsorship / Other customized sponsorship stream registration deadline   | August 22 (Fri), 2025             |
| Submission of <ul style="list-style-type: none"><li>Booth plan request: Raw space or Basic booth</li><li>LUNCH SPEAKER SESSIONS application (Diamond, Platinum)</li><li>EXHIBITOR'S SUITE application (Diamond, Platinum, Gold)</li><li>EXHIBITORS FORUM application (Diamond, Platinum, Gold, Silver)</li></ul> ➔ <a href="#">Application Form 1</a> | August 22 (Fri), 2025             |
| Submission of LUNCH SPEAKER SESSIONS information (Diamond, Platinum)<br>➔ <a href="#">Application Form 2</a>  | August 22 (Fri), 2025             |
| <ul style="list-style-type: none"><li>Exhibition space allocation</li><li>Submission of optional items and rental furniture order form</li></ul>  | Early September, 2025             |
| Invoice (sponsorship packages & other customized sponsorship streams)   | End of August, 2025               |
| Payment due date (sponsorship packages & other customized sponsorship streams)  | September 30 (Tue), 2025          |
| Submission of booth plan (raw space only)   | October 30 (Thu), 2025            |
| Submission of EXHIBITORS FORUM Information (Diamond, Platinum, Gold, Silver)<br>➔ <a href="#">Application Form 3</a>  | October 30 (Thu), 2025            |
| Optional items /Lunch order deadline  | November 28 (Fri), 2025           |
| Optional items /Lunch payment deadline  | End of December, 2025             |
| Booth setup   | January 26 (Mon), 2026            |
| Exhibition  | January 27 (Tue) - 29 (Thu), 2026 |
| Teardown  | January 29 (Thu), 2026            |

Kindly refer to the respective links for each application form.

# SPONSORSHIP REGISTRATION PROCESS

## Registration

---

Companies wishing to support SCA/HPCAsia 2026 are asked to complete the Sponsorship Registration Form.

**Registration Deadline**

**August 22 (Fri), 2025**

**Be Our Sponsor Today!**



<https://sca-hpcasia2026.kyosan.cloud>

## Sponsorship Registration and Confirmation

---

The Sponsorship Secretariat of SCA/HPCAsia 2026 will confirm the sponsor's commitment and issue an invoice upon receipt of the Sponsor and Exhibitor Reservation Form. Should multiple sponsors apply for the same sponsorship opportunity, priority may be given based on the date of receipt of the reservation form.

## Payment and Cancellation

---

### Payment

Specific directions for payment of sponsorship will be provided upon commitment, and will be accompanied by an invoice. All amounts due must be paid in Japanese Yen (JPY).

### Cancellation and Withdrawal

A cancellation is only granted in exceptional circumstances. Sponsors must send a cancellation request to the Sponsorship Secretariat of SCA/HPCAsia 2026 by August 22. If a cancellation is granted, the sponsorship fee may be refunded.

## Code of Ethics

---

This conference will be conducted in accordance with the ACM Code of Ethics and Professional Conduct, which can be accessed via the following link:

<https://www.acm.org/code-of-ethics>

## Exhibition Space Allocation

---

SCA/HPCAsia 2026 reserves the right to allocate exhibition space at its discretion.

## Secretariat

---

Sponsorship Secretariat of SCA/HPCAsia 2026

c/o Convention Linkage, Inc.

11F PIAS TOWER, 3-19-3 Toyosaki, Kita-ku, Osaka-city, Osaka 531-0072, Japan

E-mail: [sponsor-sca\\_hpcasia\\_2026@c-linkage.co.jp](mailto:sponsor-sca_hpcasia_2026@c-linkage.co.jp)

Tel: +81-6-6377-2188

# EXHIBITOR MANUAL

## Exhibition Schedule

---

- January 26 (Mon) 1) 10:00AM-8:00PM Installation  
\*For exhibitors who choose raw space (space only) and external booth builder.  
2) 2:00PM-8:00PM Installation  
\*For exhibitors who order the basic booths.
- January 27 (Tue) 9:30AM-5:30PM  
January 28 (Wed) 9:30AM-5:30PM  
January 29 (Thu) 9:00AM-3:00PM  
3:00PM-8:00PM Dismantling & removal

## Booth Design

---

Exhibitors are requested to choose one of the following two booth plans:

- 1) Raw space
- 2) Basic booth

### 1) Raw space (space only)

Exhibitors are responsible for their booth building, including the cost of construction work to set up power supply lines and for electricity use. Booth locations are indicated (marked) on the exhibition floor. All exhibitors choosing external booth builders (NOT ordering a basic booth via the Sponsorship Secretariat of SCA/HPCAsia 2026) must submit a detailed cosmetic and technical plan and obtain approval from the Sponsorship Secretariat of SCA/HPCAsia 2026. SCA/HPCAsia 2026 will not provide any introductions to external booth builders or contractors.

# EXHIBITOR MANUAL

## 2) Basic booth (with the basic booth package)

Exhibitors choosing a basic booth will receive the basic booth package listed below. They can also choose from the optional items listed under 'Optional items'.

### Platinum

(4m x 4m)

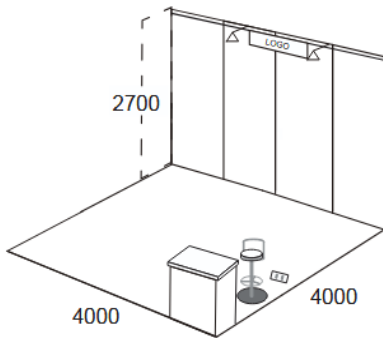

|   | Amount | Unit Price | Quantity | Total  |
|---|--------|------------|----------|--------|
| •Basic booth package                                      |        |            |          |        |
| Back panel (W990mm x H2,700mm)                            | 1      | 6,000      | 4        | 24,000 |
| Reception counter (W990mm x D450mm x H900mm) & high chair | 1      | 30,000     | 1        | 30,000 |
| Set-up & removal  | 1      | 40,000     | 1        | 40,000 |
|   |        |            |          | 94,000 |

The following items will be included in the basic booth package:  
 Company signboard, Spotlight x 2,  
 Single-phase 100V/300W outlet (2-pronged) x 1,  
 Floor:punched carpet

| •Optional items                        | Amount | Unit Price |              |              |
|--|--------|------------|--------------|--------------|
| Side panel (W990mm x H2,700mm)         | 1      | 6,000      | as requested | as requested |
| Table set (1 table & 4 chairs)         | 1      | 35,000     |              |              |
| A1 panel (printing only)               | 1      | 13,000     |              |              |
| A1 panel graphic (layout & printing)   | 1      | 27,000     |              |              |
| Side panel graphic (printing only)     | 1      | 40,000     |              |              |
| Side panel graphic (layout & printing) | 1      | 70,000     |              |              |
| Reception counter graphic              | 1      | 20,000     |              |              |

### Gold

(2m x 4m)

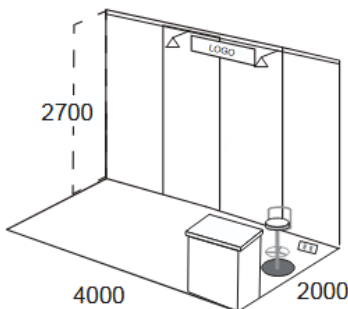

|   | Amount | Unit Price | Quantity | Total  |
|---|--------|------------|----------|--------|
| •Basic booth package                                      |        |            |          |        |
| Back panel (W990mm x H2,700mm)                            | 1      | 6,000      | 4        | 24,000 |
| Reception counter (W990mm x D450mm x H900mm) & high chair | 1      | 30,000     | 1        | 30,000 |
| Set-up & removal  | 1      | 40,000     | 1        | 40,000 |
|   |        |            |          | 94,000 |

The following items will be included in the basic booth package:  
 Company signboard, Spotlight x 2,  
 Single-phase 100V/300W outlet (2-pronged) x 1,  
 Floor:punched carpet

| •Optional items                        | Amount | Unit Price |              |              |
|--|--------|------------|--------------|--------------|
| Side panel (W990mm x H2,700mm)         | 1      | 6,000      | as requested | as requested |
| Table set (1 table & 4 chairs)         | 1      | 25,000     |              |              |
| A1 panel (printing only)               | 1      | 13,000     |              |              |
| A1 panel graphic (layout & printing)   | 1      | 27,000     |              |              |
| Side panel graphic (printing only)     | 1      | 40,000     |              |              |
| Side panel graphic (layout & printing) | 1      | 70,000     |              |              |
| Reception counter graphic              | 1      | 20,000     |              |              |

Note: Consumption tax is included in all prices.

# EXHIBITOR MANUAL

## Silver

(2m × 3m)

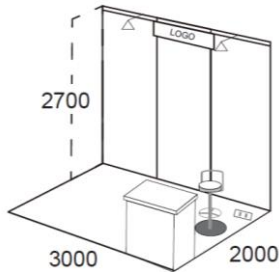

|   | Amount | Unit Price | Quantity | Total  |
|---|--------|------------|----------|--------|
| •Basic booth package                                      |        |            |          |        |
| Back panel (W990mm x H2,700mm)                            | 1      | 6,000      | 3        | 18,000 |
| Reception counter (W990mm x D450mm x H900mm) & high chair | 1      | 30,000     | 1        | 30,000 |
| Set-up & removal  | 1      | 40,000     | 1        | 40,000 |
|   |        |            |          | 88,000 |

The following items will be included in the basic booth package:  
Company signboard, Spotlight x 2,  
Single-phase 100V/300W outlet (2-pronged) x 1,  
Floor:punched carpet

| •Optional items                        | Amount | Unit Price |              |              |
|--|--------|------------|--------------|--------------|
| Side panel (W990mm x H2,700mm)         | 1      | 6,000      | as requested | as requested |
| A1 panel (printing only)               | 1      | 13,000     |              |              |
| A1 panel graphic (layout & printing)   | 1      | 27,000     |              |              |
| Side panel graphic (printing only)     | 1      | 40,000     |              |              |
| Side panel graphic (layout & printing) | 1      | 70,000     |              |              |
| Reception counter graphic              | 1      | 40,000     |              |              |

## Bronze

(2m × 2m)

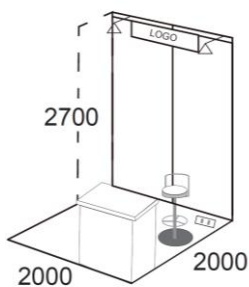

|   | Amount | Unit Price | Quantity | Total  |
|---|--------|------------|----------|--------|
| •Basic booth package                                      |        |            |          |        |
| Back panel (W990mm x H2,700mm)                            | 1      | 6,000      | 2        | 12,000 |
| Reception counter (W990mm x D450mm x H900mm) & high chair | 1      | 30,000     | 1        | 30,000 |
| Set-up & removal  | 1      | 40,000     | 1        | 40,000 |
|   |        |            |          | 82,000 |

The following items will be included in the basic booth package:  
Company signboard, Spotlight x 2,  
Single-phase 100V/300W outlet (2-pronged) x 1,  
Floor:punched carpet

| •Optional items                        | Amount | Unit Price |              |              |
|--|--------|------------|--------------|--------------|
| Side panel (W990mm x H2,700mm)         | 1      | 6,000      | as requested | as requested |
| A1 panel (printing only)               | 1      | 13,000     |              |              |
| A1 panel graphic (layout & printing)   | 1      | 27,000     |              |              |
| Side panel graphic (printing only)     | 1      | 40,000     |              |              |
| Side panel graphic (layout & printing) | 1      | 70,000     |              |              |
| Reception counter graphic              | 1      | 40,000     |              |              |

## Start-up

(1m × 1m)

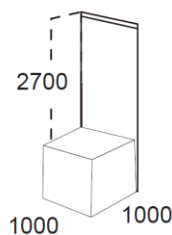

|                                |
|--------------------------------|
| •Basic booth package           |
| Back panel (W990mm x H2,700mm) |
| Display table                  |

Note: Consumption tax is included in all prices.

Additional optional items beyond those listed above may also be available.  
Please contact the SCA/HPCAsia 2026 Sponsorship Secretariat for more information.

# SPONSOR and EXHIBITOR BENEFITS

## Attendee Contact List (Diamond, Platinum, Gold)

---

Diamond, Platinum and Gold sponsors will receive the contact information of registered attendees who have agreed to share their data (name, company name, job title, email address, country) in compliance with the Japanese Personal Information Protection Act.

## Complimentary Passes

---

Conference and Exhibition passes will be issued to participating companies based on sponsorship entitlements. At least one exhibitor must always be present at the booth during exhibition hours. Sponsors can allocate the passes included in their package to any member of staff or guest of their choice.

All participants attending SCA/HPCAsia 2026 on-site must be registered. Online registration will be available in late September. Upon arrival, each participant must check-in in person at the check-in desk to receive a badge. Access will not be granted without a badge.

## Exhibition Space

---

Exhibitors are requested to choose one of the following two booth plans:

- 1) Raw space (space only)
- 2) Basic booth (with the basic booth package)

Please refer to the Exhibitor Manual for details.

## Exhibitors Forum (Diamond, Platinum, Gold, Silver) – Onsite Speaking Opportunity

---

Diamond, Platinum, Gold and Silver sponsors are entitled to a 15-minute talk in the Exhibitors Forum. This is an Industry Session open to all attendees. Sponsors wishing to participate in the Exhibitors Forum are requested to submit the application form to the Sponsorship Secretariat of SCA/HPCAsia 2026. Please complete the application form on page 6 and submit it by the deadline.

Speakers of the Exhibitors Forum must register using one of the complimentary passes included in their sponsorship package or with a paid pass (either conference or exhibition pass).

- Date: January 27 (Tue) - 29 (Thu), 2026
- Venue: 3F Exhibition Hall
- Exhibitor Forum hours: 1:30 PM - 5:30 PM (tentative)
- Capacity: Theater-style with 30 seats and some high tables
- Length of the talk: 15 minute for each sponsor / 10-12 slots per day

\* Speaking slots will be assigned by the Sponsorship Secretariat of SCA/HPCAsia 2026 based on each sponsor's request.

# SPONSOR and EXHIBITOR BENEFITS

## Items included in the Exhibitors Forum

- Standard AV setup, including projection screen
- One podium and one laptop with a live screen feed
- Microphones (one podium microphone, one microphone for the moderator)
- Sound system
- Chairs and high tables for the audience

## Submission Process

1. Application Form for Exhibitors Forum
2. Session information
  - Title of the talk
  - Speaker information (name, affiliation)
  - Session description

Note: Please refer to page 6 of the Sponsorship Registration Process for the deadline.

## Exhibitors Suite (Diamond, Platinum, Gold)

Sponsors may apply for an Exhibitors Suite (full day). Diamond and Platinum sponsors will be given priority. The Sponsorship Secretariat of SCA/HPCAsia2026 will provide an application form to each sponsor individually in accordance with the registration order.

## Logo Exposure

All SCA/HPCASia2026 sponsors and exhibitors will have the opportunity to display their logo on the official website and in general conference materials. Sponsors will be asked to submit their official logos.

## Lunch Speaker Sessions (Diamond, Platinum)

Diamond and Platinum sponsors are entitled to a 60-minute session during lunch time. Sponsors wishing to hold a Lunch Speaker Session are requested to submit the application form to the Sponsorship Secretariat of SCA/HPCAsia 2026. Please complete the application form on page 6 and submit it by the deadline.

### Room Information

| Date & Time | Date & Time   | Available rooms | Capacity                        | Lunch Style        |
|-------------|---|-----------------|---------------------------------|--------------------|
| Type A      | January 27 (Tue) - 29 (Thu), 2026<br>12:00 PM-1:00 PM (tentative) | 3               | Theater-style,<br>400 seats     | Buffet / Bento box |
| Type B      | January 27 (Tue) - 29 (Thu), 2026<br>12:00 PM-1:00 PM (tentative) | 12              | Theater-style,<br>170-190 seats | Bento box          |

# SPONSOR and EXHIBITOR BENEFITS

- Sponsors are responsible for the program, including lunch arrangements.
- If the stage layout is changed to accommodate the activities such as panel discussions, sponsors are responsible for returning the room to its original configuration within their allocated time.
- Prior registration will be requested for the participants who wish to attend the session.

## |Items included in the session

- Theater-style setup with a stage
- Standard AV setup, including a projection screen appropriate to the room size
- One podium and one presentation system (PC and monitor) with a live screen feed, mouse, slide advancer, and monitor at the moderator table
- Microphones (one podium microphone, one table microphone for the moderator table, and floor microphones for audience Q&A)
- Sound system and stage lighting

## |Items NOT included in the session

- Cost of lunch arrangements
- Additional equipment

## |Submission Process

1. Application Form for Lunch Speaker Session

2. Session information

- Title of the presentation
- Speaker information (name, affiliation and photo)
- Session description

3. Lunch Ordering Form

The number of pre-registered participants as of mid-November will be shared by the Sponsorship Secretariat of SCA/HPCAsia 2026. Please complete your order by the designated deadline. For the lunch ordering schedule, please refer to page 6.

## **Promotional Materials**

---

One (1) corporate brochure (maximum size: A4) and one (1) corporate gift can be inserted into the conference bag. Sponsors wishing to insert promotional materials are required to ship them by the specified time and to the specified place.

# GUIDELINES and POLICIES for EXHIBITION

## **Cancellation or Closure of Exhibition**

---

The exhibition may be cancelled or closed at the discretion of the organizers if it becomes impossible or impractical to hold the event due to natural disasters or other force majeure circumstances. In such cases, the organizers shall not be liable for any loss or damage incurred by the exhibitor, and sponsorship fees may not be refunded.

## **Demonstrations**

---

Exhibitor demonstrations must not interfere with normal traffic flow or infringe on neighboring exhibits. Demonstrations are not permitted outside the exhibitor's assigned space.

## **Facility Regulations**

---

Exhibitors are required to comply with all facility regulations regarding the design, installation, operation, and dismantling of their exhibit stands. A complete description of electrical, fire, labor, and property regulations will be provided in the Exhibitor Manual, which will be updated in early September.

Please also review the Osaka International Convention Center (OICC) facility information, safety measures and other guidance.

[OICC Usage Guide](#)

## **Food and Beverage Distribution**

---

Exhibitors wishing to serve or distribute any food or beverages from their assigned exhibit space must notify the venue and, in principle, use the designated catering company. Additional fees will apply to those bringing in outside catering. Further information will be provided in the Exhibitor Manual, to be distributed in early September.

## **Liability**

---

The exhibitor shall be fully responsible for any and all damage to property owned by the venue, its owners, or managers, resulting from any act or omission by the exhibitor. The exhibitor agrees to defend, indemnify, and hold harmless SCA/HPCAsia 2026, along with its owners, managers, officers, directors, agents, employees, subsidiaries, and affiliates, from any claims, damages, or charges arising from the exhibitor's use of the property.

This liability includes, but is not limited to, all losses, costs, damages, or expenses resulting from any accident, bodily injury, or other incident involving any person (including the exhibitor, their agents, employees, or business invitees) that occurs as a result of the exhibitor's occupancy or use of the exhibition premises, the venue, or any part thereof.

In addition, the exhibitor should acknowledge that SCA/HPCAsia 2026, the venue, and all related service providers do not insure the exhibitor's property. It is the sole responsibility of the exhibitor to obtain appropriate insurance, including business interruption and property damage coverage, for any potential loss.

# GUIDELINES and POLICIES for EXHIBITION

## Merchandise Sales

---

Selling merchandise is prohibited at SCA/HPCAsia 2026.

## No Smoking

---

Smoking is prohibited in all public areas of the venue.

## Promotional Items

---

A promotional item approval form which will be included in the Exhibitor Manual must be submitted to the Sponsorship Secretariat of SCA/HPCAsia 2026.

Exhibitors wishing to use the official conference logo on their promotional materials must submit a sample, photo, or written description of each item to SCA/HPCAsia 2026 for prior approval.

The conference official logo is available from [here](#)

## Relocation

---

SCA/HPCAsia 2026 reserves the right to relocate exhibitors. If it becomes necessary to relocate an exhibitor after a specific space has been assigned, SCA/HPCAsia will notify the exhibitor. Every effort will be made to reassign the exhibitor to a comparable space.

## Restriction of Exhibits

---

SCA/HPCAsia 2026 reserves the right to:

- (a) reject any application to exhibit at the SCA/HPCAsia 2026 for any reason;
- (b) prohibit, restrict, or require modification of any exhibit for any reason; and
- (c) evict or bar any exhibitor whose exhibit, materials, or conduct is deemed objectionable for any reason.

Violation of any regulations by the exhibitor, their employees, or agents will result in the forfeiture of the right to occupy the space, and all fees paid will be retained by SCA/HPCAsia 2026.

Upon evidence of such a violation, SCA/HPCAsia 2026 may enter and take possession of the space occupied by the exhibitor, removing all persons and goods at the exhibitor's risk. The exhibitor shall be responsible for any expenses or damages incurred by SCA/HPCAsia 2026 as a result.